

UV Generator PE22 to PE90

22 to 90m³/h



DISINFECTION

UV GENERATOR

PE22 to PE90 UV

UV generator for disinfecting corrosive liquids and sea water at a flow rate of 22 to 90m³/h, the PE range addresses many applications.

Control box with electrical protection, LCD display dry alarm transfer contact and remote On/Off contact.



SPECIFICATIONS

- Generator built of PEHD.
- UVc dose of 400 J/m² for water with transmittance of 99% @ 1cm, 20°C.
- Lamp life duration ~ 9000 h.
- Protection index: IP54.
- Vertical or horizontal mounting.
- Immediate bactericidal effect
- No water storage necessary
- No chemical products used.
- No change in the physical-chemical quality of the water.
- Possibility to install several units in parallel.

APPLICATIONS

- Disinfection of corrosive waters.
- Disinfection in pre-treatment of sea water desalination.
- Disinfection of water for aquaculture.
- Disinfection of water for aquariums.

PE22 to PE90 UV Generator

TECHNICAL CHARACTERISTICS

	PE22	PE35	PE45	PE61	PE90
Peak flow rate (m ³ /h)	22	35	45	61	90
Number of lamps	3	4	5	2	3
Lamp life duration (h)	9000 h				
UV-C dose (J/m ²)	400				
Construction	PEHD				
Connection (input/output)	DN65	DN80	DN100	DN100	DN150
Maximum duty pressure (bar)	6				
Electric power supply	230V - 50/60 Hz				
Power (W)	240	320	400	440	660
Protection index	IP 54				
Fault LED	Yes				
LCD display	Yes				
Time meter	Yes				
Resettable count down hour-meter	Yes				
Fault contact (dry)	Yes				
Fault relay 230V NO/NC outlet - 2 A max	Yes				
On/Off timer	Yes				
Remote On/Off contact	Yes				
Irradiation dose display	PLUS Version				
Temperature display	PLUS Version				
Stop at high temperature	PLUS Version				
Control box dimensions (mm)	Optional only for PLUS Version				
Contact 4/20 Ma	400 x 300 x 200		500 x 400 x 200		



LCD2 (PLUS)

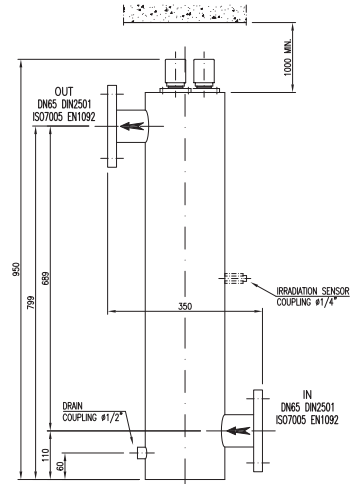

PE22

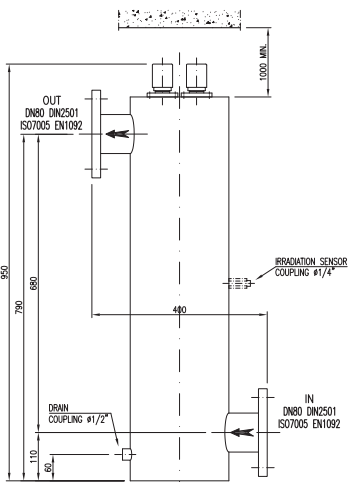

PE35

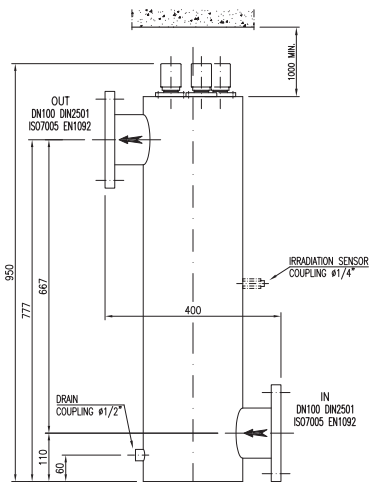

PE45

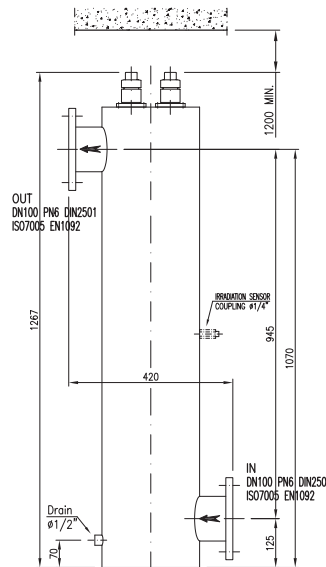

PE61

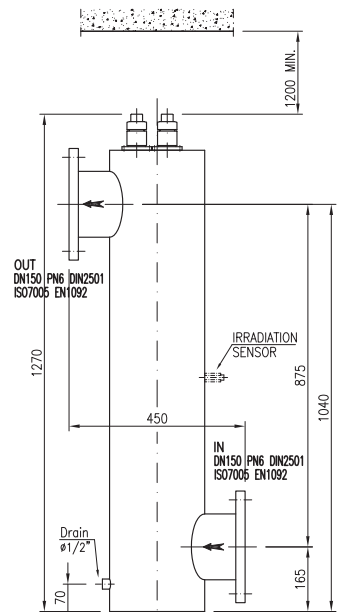

PE90

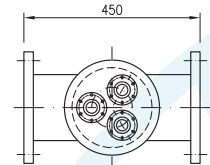

ADH2OC INDUSTRIAL
 Headquarters
 3, Rue Kercoz
 22 220 TRÉGUIER - FRANCE
 Tel +33 (0)2 96 40 02 50
 Fax +33 (0)2 22 44 98 48
 www.adh2oc-industrial.com

Workshop
 Lieudit «La Vallée Drouard»
 28500 CHÉRISY - FRANCE
 Tel +33 (0)2 37 50 20 79
 Fax +33 (0)2 22 44 98 48
 e-mail : infos@adh2oc-industrial.com